



Palomar R/C Flyers, Inc.

Transmitter

JUNE
2014



AMA Charter #141

Build & Fly

PRESIDENT'S COLUMN



This past Memorial Day weekend the Palomar RC Flyers hosted the San Diego Heli Fun Fly. The event was promoted by Heli chairman Philip Degarmo with some help from Scott Dedic. Thanks to Horizon Hobby, Assurance RC and Align, and Sirocco Helis for sponsoring this event, it was fun giving away a new DX9 radio not to mention a number of nice heli kits! With 71 pilots registering the event was very successful and everybody attending seemed to have a great time. Thanks to Joe Villarreal for heading up the cooking team, Jim Jenkins for all his help keeping the flight line safe, Tom "Blackie" Blackburn for first aide all weekend, Patrick Pranica, Bob Broughton, Mike Lonnecker for keeping the registration and raffle table up to speed. Also want to recognize Scott Page, and Bob Frazier for having my back all weekend and the help with set up and tear down. I know I'm leaving many of those that helped unmentioned but know that I appreciate all the help and support that you all gave to make this an outstanding event.

I submitted my resignation this past month and will no longer be serving as your club president. Varley Longson has been appointed by your board of directors to fill in temporarily as president until a new president can be elected. Nominations will be taken at the June 19th club meeting and a vote will be conducted at the following meeting July 17th. I urge the membership to please support Varley in his endeavors to guide the club thru this process and I urge any members who have ever thought about contributing to step up and run for this office.

Before closing let me make a few suggestions that might make running the club a little simpler. First; does the club really need to meet every month? I know that it's a social event, but don't we socialize at the field? How about having quarterly meetings at the field? It seems like it might be fun to have an event at the field like the Fourth of July picnic that would also serve as a club meeting. This would also save the cost of renting a meeting room. Does the Board of Directors need to meet every month? It seems to me that bimonthly meetings would be ample to take care of club business and emails could fill in as needed. With the excellent news letter and a dynamic website the membership could be kept informed.

Let me express my gratitude to the membership for all the positive support you've given me thru these past couple of years. This is an outstanding group of people and I've been privileged and proud to have served in this lead position. Thank you all!

Bill Hill

Board Meeting Agenda May 28, 2014

Participants: Scott Dedic, Joe Villareal, Roger Cosio, Chuck Riley, Bill Hill, Denver Bates, Chris Avellino, Sean O'Connor, Varley Longson, Patrick Crannica, Jim Jenkins

Start time: 7:00 p.m.

End Time: 8:27 p.m.

Treasurer Report: \$43,800

Appoint temporary President to fill vacancy. Discuss procedures to finalize position by vote of membership.

Varley Longson filling the role until a new president appointed.

Heli Fun Fly results, report; Bill Hill

Netted \$2,500 on the event

71 pilots registered

Overall positive feedback and discussed pros/cons and areas of opportunity to improve next year's event. For example:

Change number of pilot stations

Create noon-demos

Pilot briefings done multiple times a day and via various communication mediums.

Fill vacancy, Club Safety Officer, discuss.

Jim Jenkins to stay in his current role.

Status new website?

Peter to bring the new site to the board for the next meeting.

Field maintenance; shade cover columns at Heli side. Action plan.

Need to do an assessment at the Heli side and see if we need to make repairs.

Combat; June 14th plan

Change of date to the 14th.

Noise issue, report and discuss

Bill, Chris and Varley provided results from their respective samples/audits and all passed.

Club members asked to stay within compliance of club and DB rules. Please do not fly outside of approved hours.

Chris Avellino Club Secretary

The May 15th club meeting was cancelled due to the fires along the Highway 78 corridor. Thus, there was no model of the month.



President Emeritus George Dawe took this photo in Fallbrook, CA during the height of the fires that ravaged the land. In Carlsbad, CA, club member John Binikos saw 50' high flames 100' from his home. He kissed his home good-bye and left! When he returned, two homes were standing, and one of them was his! A helicopter dropped water on his home and saved it!



Heli Chairman Philip Degarmo promoted the very successful Heli-Fun-Fly. Many thanks Philip!

Multiplex CULARIS Motor Glider or Pure Sailplane or BOTH

By Jim Gallacher

jgallacher@nethere.com

I have a *Multiplex Cularis* motor glider, it's a good all-around sailplane. I have a 3m *HF ASW28* hollow molded fiberglass glider. This one needs to be aerotowed. I come from a back ground of full scale gliders with almost 900 aerotows but NONE were done from the ground as with RC aerotowing. Knowing how hard just flying a model was in the beginning I figured I needed an aerotow trainer. What better choice but the *Multiplex Cularis*? I fly this plane almost every day.



I know it inside and out so all there is to do is learn to fly the tow. In the Cularis the only problem is the lack of space for the tow release servo with the motor up front as seen in the photos below.

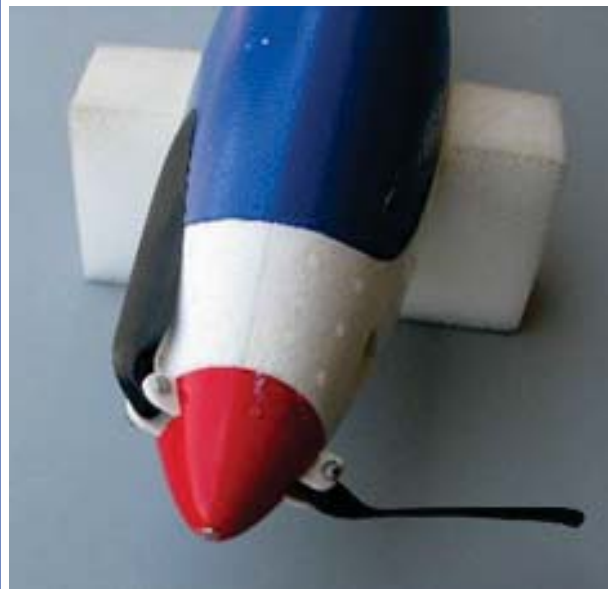

I removed both the motor and the speed controller. I use a Castle 10Amp BEC and the same 3S LiPo 2200ma battery that is used for the motor glider mode.

I made an aluminum adapter that fits in place of the motor. Below is a copy of the drawing I used to make the adapter.

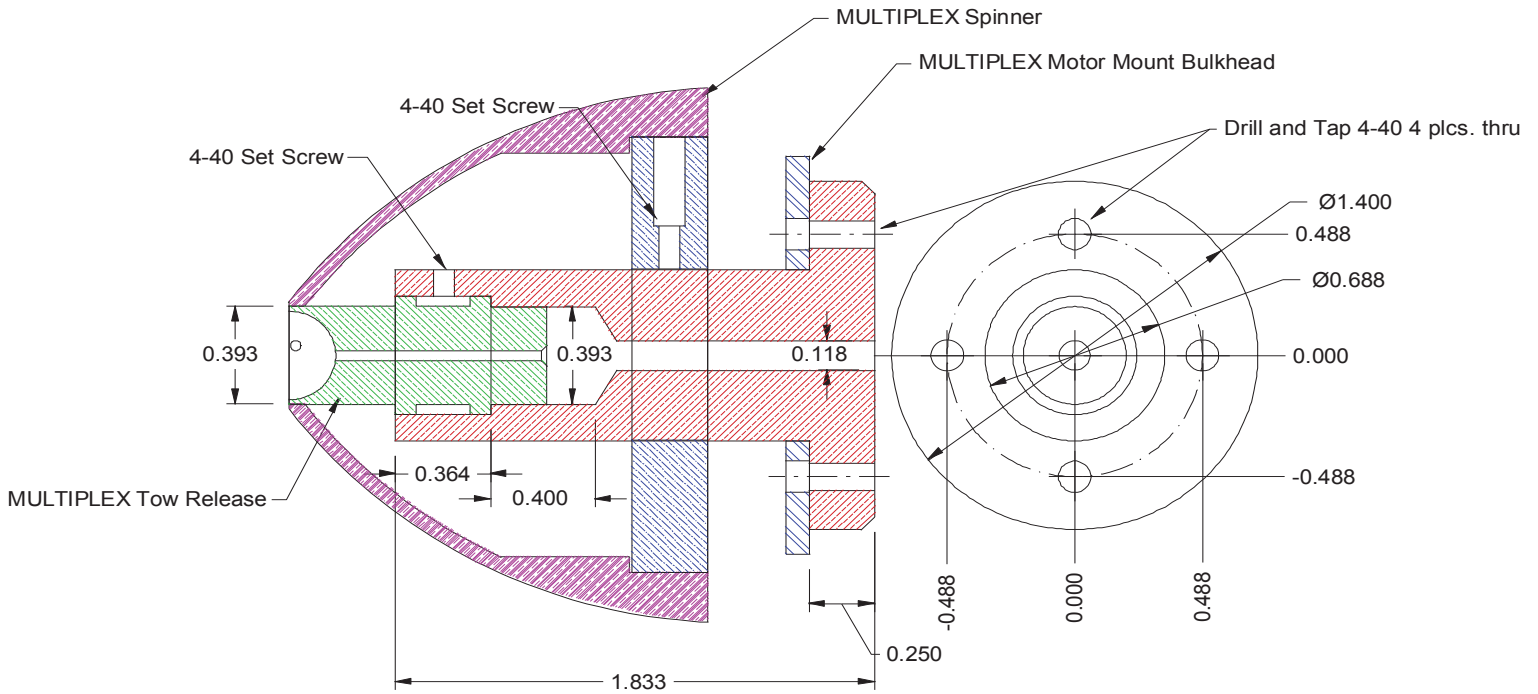

This adapter uses *Multiplex* tow release # MPU72340, sold for about \$7.00. This *Multiplex* adapter is inserted into the aluminum adapter I made and is locked in place with a 4-40 set screw. The spinner has an internal step in the big end I put a 3/8 thick aluminum disk with a hole large enough to fit over the aluminum shaft then used a 4-40 set screw to hold it in place. The spinner is screwed to the aluminum disk using flat head 4-40 screws. This can be seen in the photos below.



Multiplex in their infinite wisdom molded a place for the tow release servo. All that is needed is to attach some thin plywood to the foam for the servo screws to screw into. This can be seen below.

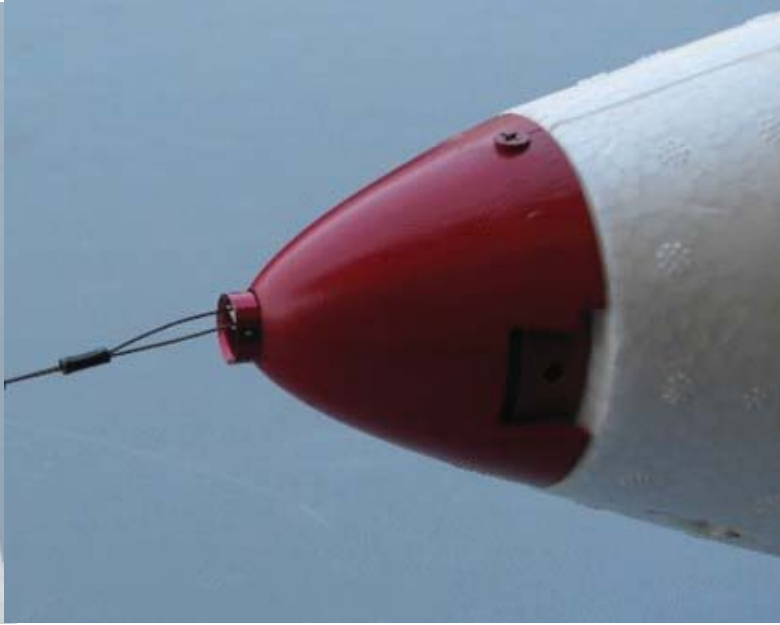

Because of the difference in weight between the motor and the aluminum aerotow adapter I had to add some lead to the nose. I attached the extra weight to the front side of the release servo. The conversion from one mode to the other can be done in about 5 – 10 minutes. By the way, aerotow with the Cularis is easy, just keep the wings as level as you can and let the tow plane turn you. Don't let the unknown stop you from trying this method of RC soaring.





James D'Eliseo sent these photos of his 3-D Extra. When James flies, everyone else happily gives him the sky because he puts on an unbelievable show!



James flies in a class by himself! It is a treat to watch him wring out a plane and make it fly slowly and deliberately with precision.





http://i.telegraph.co.uk/multimedia/archive/02902/POTD-Model-Planes_2902499k.jpg

A montage of 89 of the 350 scale model planes which are being auctioned by Dominic Winter auctions!! The intricate models, some with parts as fine as a human hair, were all made by the same craftsman over the course of 50 years. The collection includes models of nearly every plane built before WW1

Col. Bob Broughton, USAF Ret. relaxes at the field on May 27, 2014. The temp was 80 but the wind gusted to 25 mph.

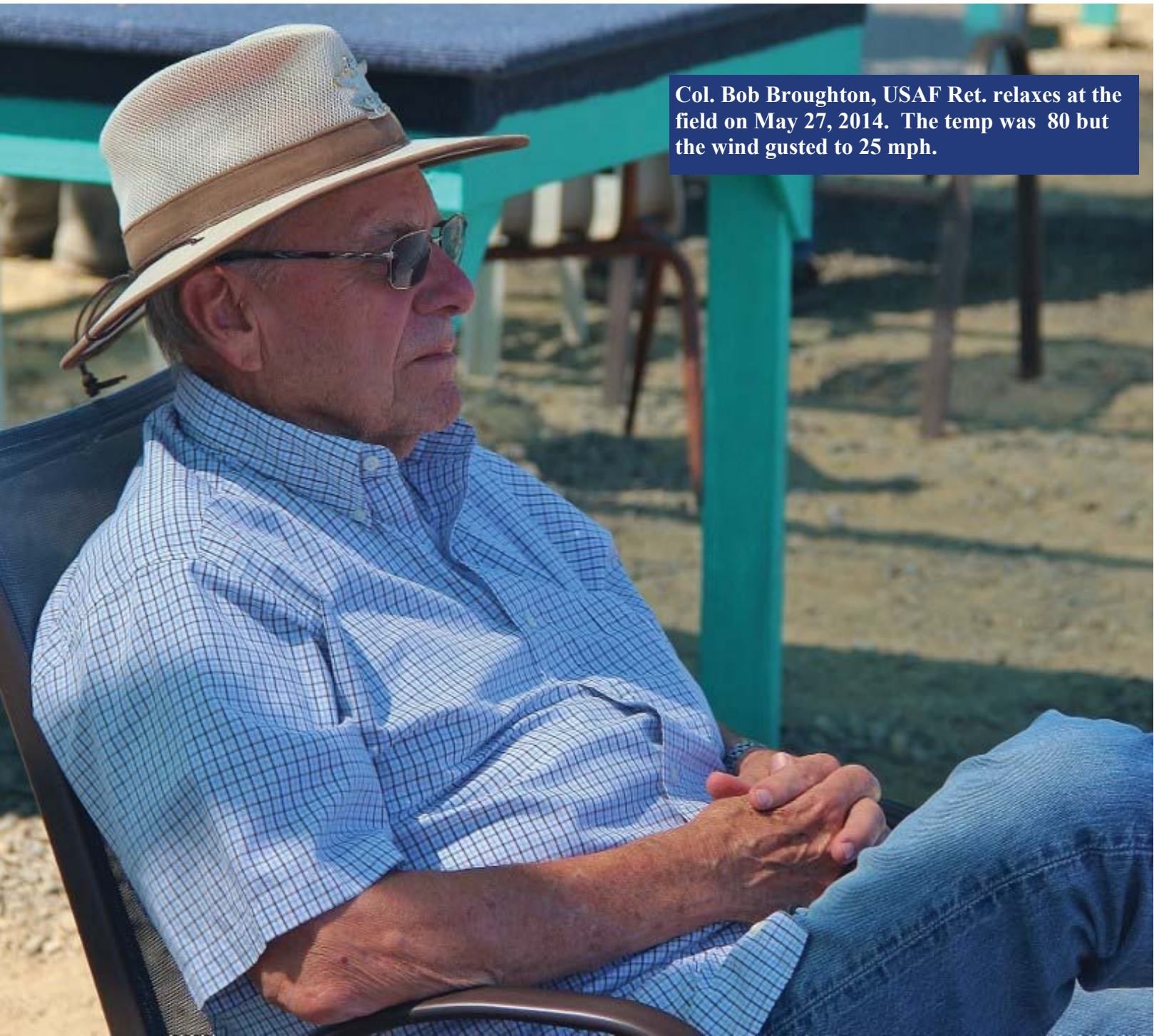

Ed Ramsey lands his gasoline powered hefty Mustang with authority on May 27, 2014.



The San Diego Air and Space Museum has completed their non-flying build of the Bell X-1, and installed it in their entry! It is so impressive and sleek. We watched them build this plane in the downstairs of the Museum where all their tools and machines are located. The fine craftsmen should be so proud of this magnificent build.



Don Wadlington test ran his new 182 Saito twin which will power his new Piper Cub. Steve Hoy is the giver of horns.

When Don was flying the other day, one of our outhouses was blown over! Fortunately, Don wasn't in it when it happened. Thus, Don issued a safety warning: "When the outhouse blows over, it's too windy to fly!" Thanks Dave for that great tip which we would have never figured out. NOT!

San Diego Heli Fun-Fly May 23-25, 2014



Col. Robert Broughton photo



Scott Page's Huey

71 Heli Pilots flew in our San Diego Heli-Fun Fly event this year; it was a great success. Thanks to all who participated, from the pilots to the cooks, the set-up and take-down crews, the registration team, the spotters, the safety coordinator, and especially to Bill Hill our president who worked tirelessly to make this event so fine. Thanks to the publicity folks, our field preparation team, the raffle people, vendors, and the other unsung heroes who worked on this event!



Expert pilot Ray Nemovi (pointing) and friend Steve



Scott Page and his Viet-Nam era Huey. It looks full-scale!



Alfonso Alvarez flew his colorful heli on a picture-perfect afternoon at the Fun-Fly.



Safety Coordinator Jim Jensen and President Bill Hill take a few minutes out of their busy schedules.



Some of the many canopies that lined the runway. That's Steve Nelson on the extreme right.



Steve Hoffmann and Don White relax on Friday at the start of the Fun-Fly.



Ray Nemovi flew his TREX up close for this photo.



Bob Murray works his bird before flying it.



Bob Murray

Blackie

a Horizon Hobbies Flyer

James D'Eliseo , his wife Kristen and Dave Litaker made the cross country trip to Triple Tree Aerodrome on Hartness Field, Greenville, South Carolina for the 2014 Joe Nall Giant Scale Fly-In. It was held May 12, 13, 14, 15. The following photos were taken by James or Kristen at the Fly-In. Below is a photo of the camping area where some of the people who attended the event stayed. 1,400 pilots registered!!





James drove his trailer loaded with airplanes to the massive event.



Curtis Pineau



Dave Litaker





Curtis Pineau now works in North Carolina.



A BIG beautiful Christen Eagle



An idyllic day @ Joe Nall brought out many beautiful large birds.



Kristen D'Eliseo and Curtis Pineau with James in the background. This was taken on the last day of the event when most folks had already left.



Kristen D'Eliseo





This is the last photo of the Joe Nall event. Thanks James and Kristen!

AS SEEN AT THE FIELD BY ETHEL BURKE

The next two photos were taken by Ethel.

Alan Wolstenholme had a successful maiden flight with his new ME-109 Messerschmitt ARF from Hangar 9. The wing-span is 64 in. and has inner and outer flaps. It weighs 11 lbs. 10 oz.

It is powered by an OS-95AX two-stroke glow engine with a 3-blade 14 x 7 prop. It has E-flite electric retracts from Horizon Hobby, and it is flown with a JR-9503 radio.





Frank Burke is flying this new Corsair ARF from Global Hobbies. It has a 53 in. wingspan with fixed landing gear. It is powered by a Magnum 52 four-stroke glow engine with an 11 x 6 prop. It weighs 5 lbs. 11 oz. and has a 26 oz. wing load.

CHRIS	AVELLINO	125.00
DENVER	BATES	125.00
THOMAS	BLACKBURN	125.00
ROBERT	BROUGHTON	125.00
ROGER	COSIO	125.00
SCOTT	DEDIC	125.00
ROBERT	FRAZIER	125.00
BILL	HILL	125.00
TIM	HITCHCOCK	125.00
JIM	JENKINS	125.00
VARLEY	LONGSON	125.00
MIKE	LONNECKER	125.00
SEAN	O'CONNOR	125.00
GLENN	POHLY	125.00
PATRICK	PRANICA	125.00
CHUCK	RILEY	125.00
G JOSEPH	VILLARREAL	125.00
JAMES	GALLACHER	100.00
SCOTT	PAGE	100.00
RAYMOND	FISCHER	90.00
GEORGE	DAWE	70.00
JOHN	McLEAN	70.00
DALE	BURLINGTON	60.00
RONALD	SCHUYLER	60.00
JAN	HARALDSSON	50.00
DON	WADLINGTON	50.00
ALFONSO	ALVAREZ	40.00
JOSEPH	BUKOVCHIK	30.00
PHILIP	DEGARMO	30.00
FRED	EIVAZ	30.00
JOHN L	McDONALD	30.00
RAY	NEMOVI	30.00
DONALD	WHITE	30.00
JOHN	CUTLER	20.00
ROY	DeMILLE	20.00
JOHN	GRIMM	20.00
JOHN	MALMQUIST	20.00
TOM	MINEGAR	20.00
STEPHEN D	STUART	20.00
GREG	WILSON	20.00

Palomar Dollars as of May 29, 2014. Varley Longson, Membership Chairman



High Quality Servo Extensions, Adaptors, Harnesses and More . . . All at Inexpensive Prices

Heavy Duty Extensions
LiteWire Extensions
Y Connectors
Twisted Extensions
Custom Extensions
Charge Leads
Servo/Battery Leads
Connectors
Bulk Wire
Deans, EC3, XT60, TRX,
Tamiya, JST Adaptors

Sales@Servowires.com
760.666.2738

Servowires.com has the **largest selection of servo extensions and leads** on the Internet. Our RC Battery Connectors section has **every type of battery connector and adaptor** that you need. Our custom section lets you create virtually any combination you can dream up.

FREE shipping is available to any USA address.
Money-back guarantee on all products!

Use Coupon Code "PalomarRC" to receive a 10% discount.

www.Servowires.com



COMPLETE MACHINE SHOP & AUTO PARTS

Cylinder Head Specialist

Line Boring

Hine's Computerized Engine Balancing

Cylinder Boring

Flywheel Grinding

Drum Turning

Rotor turning

Crank Kits

Engine Kits

Wet Magnafluxing

Complete Engine Rebuilding

FOREIGN & DOMESTIC AUTO PARTS

*Family Owned & Operated
34 years experience*

Complete line of Foreign & Domestic Auto Parts at Competitive Prices



Monday-Friday 8 am to 6 pm
Saturday 8 am to 4 pm



Palomar RC Flyers

Pay the same price that your mechanic or repair shop does when you present your club card at the time of purchase.

760 - 746-6110

**1960 W. MISSION ROAD - SUITE 1-5 - ESCONDIDO
(Just East of Nordahl)**

For The Best in

401 K Plans

Mutual Funds

Retirement

Investments

Long Term Care

Insurance

Call
Tom Minegar
800-585-0035

Club Directory

CLUB OFFICERS

PRESIDENT Bill Hill	760-738-0644
VICE PRESIDENT Patrick Pranica	442-333-9024
SECRETARY Chris Avellino	858-245-3342
TREASURER Sean O'Connor	858-485-0750
MEMBERSHIP CHAIR Varley Longson	760-723-1335
BD MEMBER Denver Bates	760-728-2880
BD MEMBER Scott Dedic	858-674-4624
BD MEMBER Chuck Riley	951-693-5679
BD MEMBER Roger D. Cosio	760-724-4926
BD MEMBER Joseph Villarreal	760-749-7029
BD MEMBER Tim Hitchcock	760-458-8961

CLUB OPERATIONS

Advertising Bill Hill	760-738-0644
Newsletter Editor Joe Buko	760-726-8831
WebMaster Barry Hirschberg	760-635-0025

SPECIAL INTEREST GROUPS

RC Combat Chairman Fred Eivaz	817-714-2379
Helicopter Chairman Philip Degarmo	979-204-7767

HEAD INSTRUCTOR

Dennis Newbeck	760-297-1134
-----------------------	---------------------

SAFETY COORDINATOR

James Jenkins	760-910-4141
----------------------	---------------------

INSTRUCTOR LIST

Arnon Bourner Basic Flight	858-385-0807
Butch Abongan Basic Flight	760-855-2162
David Drowns Basic Flight	760-740-1715
Todd Melton Basic Flight	760-305-8983
Glenn Pohly Basic Flight	858-414-9749
Tim Hitchcock Basic Flight	760-458-8961

Please direct correspondence to:

**PALOMAR RC FLYERS, Inc.
P.O. BOX 141
SAN MARCOS, CA 92079**

Fax :909-679-7465

E-MAIL: info@palomarrcflyers.org

Catch us on the web at:www.palomarrcflyers.org

2014 Club Officers



Treasurer Sean O'Connor

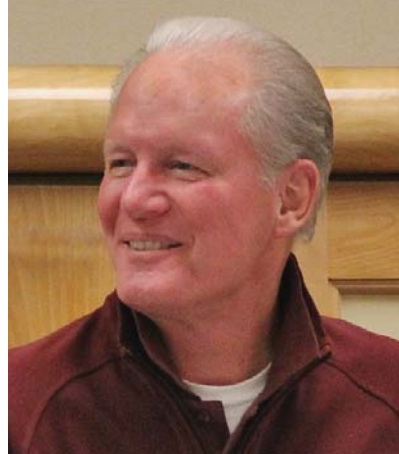

Vice President Patrick Pranica

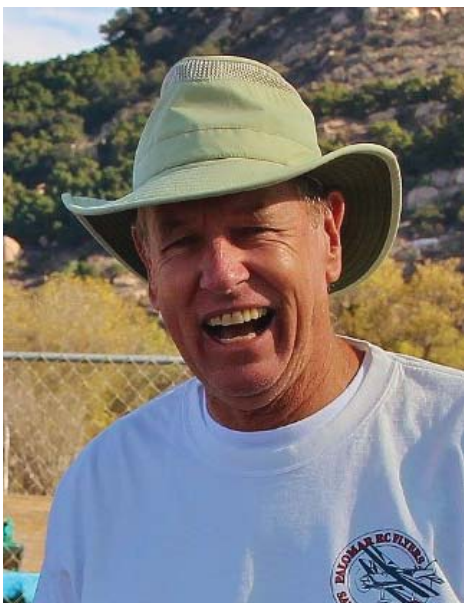

President Bill Hill



Secretary Chris Avellino



Membership Chairman Varley Longson

Board Members



Sott Dedic



Joseph Villarreal



Tim Hitchcock



Chuck Riley



Denver Bates



Roger Cosio



CLUB MEMBER NEWS

★ New Products ★ Deals ★ Events ★ Coupons ★

JUNE
2014



GET READY FOR SUMMER SALE!



Electric-Powered Readiness Coupon

Good For 50% OFF Any Or All Of These 4 Items*

Battery Alarm

2-8S LiPo/Li-FE
with Volt-Check

No. 118531
Regularly \$9.99

HALF OFF! 4.99

Exp. 6/30/14, Limit 2



Watt Meter

In-Line, Volts,
Curr, Watts,
Energy

No. 118501
Regularly \$29.99

Exp. 6/30/14, Limit 2

HALF OFF! 14.99



Battery Safety Bag

(9 x 12in)

No. 180501
Regularly \$16.99

Limit 2
Exp. 6/30/14

HALF OFF! 8.49



Strap Mounts Medium, 20x300mm (pair)

No. 118592
Regularly \$5.99

Exp. 6/30/14, Limit 2

HALF OFF! 2.99

SAVE \$7.00

HP Hobby People
Ultimate Power
11.1 Volt 2200mAh
3S LiPo T-Conn.

30C

SALE 9.99

No. 118387

Reg. \$16.99

NOBODY BEATS THIS LOW PRICE!

No. 118380-11.1V 1300mAh (3S) T-Conn ... 11.99

No. 118388-14.8V 2200mAh (4S) T-Conn ... 28.99

No. 118390-11.1V 3200mAh (3S) T-Conn ... 32.99

No. 118391-14.8V 3200mAh (4S) T-Conn ... 39.99

No. 118395-11.1V 4500mAh (3S) 43.99

No. 118396-14.8V 4500mAh (4S) 54.99

No. 118397-18.5V 4500mAh (5S) 63.99

Build Your Own Quad

HELIX

F450 Quad

DIY Starter Kit

Kit includes frame, 2212 motors, adapters, props, 30A ESCs, and Super 4-6 Flight Controller. (Battery, charger, radio, etc., sold separately)

MP 163301
List \$249.99

Now Only 199.99



*Valid June 1 through June 30, 2014 -- Retail store sales only, must present coupon at time of purchase for discount. Cannot be combined with other offers.



Hobby People

17 Hobby People Stores To Serve You
In Southern California and Nevada!

CALIFORNIA:

El Cajon
Fountain Valley
Lakewood
Murrieta
Riverside

Encino
Hesperia
Lawndale
Pasadena
San Diego

NEVADA:

Las Vegas North

Fast, Friendly, Knowledgeable,
Ask The R/C Pros!

The Crew



Lake Forest
Orange
Redlands
Santa Clarita
Camarillo
Las Vegas East



IMPORTANT REMINDER:

If you have not been receiving Hobby People e-mails lately, you need to go online and renew your **FREE** subscription.

www.hobbypeople.net

Find A Store: 1-866-HOBBY4U

hobbypeople.net

